

DESIGN AND ANALYSIS OF THE FRAME STRENGTH OF WASTE TRANSPORTING MACHINE USING SOLIDWORKS

by 1 1

Submission date: 22-Jan-2023 10:30AM (UTC-0500)

Submission ID: 1996934542

File name: 35-42_AAN.pdf (317.22K)

Word count: 2318

Character count: 11072

DESIGN AND ANALYSIS OF THE FRAME STRENGTH OF WASTE TRANSPORTING MACHINE USING SOLIDWORKS

Abdul Rahman Agung Ramadhan^a, Abdul Muchlis^b, Ibnu Fajar Ridha Ghanni^c

^{a, b, c}Industry Technology / Mechanical Engineering, Gunadarma University

*Corresponding Email: abdulrahman02@staff.gunadarma.ac.id

ABSTRACT

Garbage is a problem of concern worldwide. Public awareness in disposing of waste that is not in its place causes various kinds of problems, one of the problems that occurs is in rivers or artificial canals. This is what makes many people create tools to make it easier to control improper waste disposal. One of the tools that was created was a garbage collector, in making the design of a garbage collection machine using solidworks software, Galvanized Steel material was used with a rod size of 30 x 30 x 2.6 (mm) as the frame. With a frame size of 1320 mm in length, 790 mm in width and 1133 mm in height. The results of the simulation using solidworks software on the frame of the garbage collection machine are to get the von misses stress value with a maximum stress value 75.38 N/mm² (MPa) and a minimum stress value of 0.06 N/mm² (MPa), for the displacement value with a maximum stress value of 0.61 mm and for a minimum stress value of 0.00 mm, the safety factor gets a value of 3.55 ul. In the comparison of solidworks and theoretical software values, the value for von misses stress is 0.04%, for displacement is 0.24%, and for safety factor is 0.20%.

Keywords: Galvanis steel, Garbage, Safety factor, Solidworks, Von misses stress.

1. INTRODUCTION

The urban environment is a place where individuals come from various places and carry out activities of various forms, technological developments play a major role in population growth in urban environments, riverbanks, this is also a daily activity.

Currently, many waterways are not functioning properly due to human activities. Public awareness in disposing of waste that is not in its place causes various kinds of problems, one of the problems that occurs is in rivers or artificial canals. Garbage that is contained in rivers or artificial canals in large quantities certainly reduces the function or can even damage existing infrastructure. This can result in obstructed water flow, so that the water flow can overflow and inundate the surrounding area. In general, river waste handling is carried out using human power as the main cleaner and some use heavy equipment as an auxiliary tool. Seeing this problem, we need a garbage cleaning conveyor system in waterways that functions as a tool to reduce waste carried by water in waterways so as to prevent flooding. The desired garbage cleaning conveyor system is a tool that is inexpensive and has minimal maintenance costs and equipment usage costs and can be applied in various places.

The purpose of this writing is as follows: a) Designing the framework of a garbage collection machine with a conveyor system, b) Knowing and analyzing the values of von misses stress, displacement, and factor of safety from the design of a garbage transport machine frame with a conveyor system that simulates static loading using solidworks 2021 software.

2. RESEARCH METHODOLOGY

2.1 Design and Analysis of Garbage Transport Machine Frame

In the process of making the design of a garbage collection machine, there are several process steps that need to be passed, as shown in the flowchart diagram of the design and analysis of the frame of the garbage collection machine.

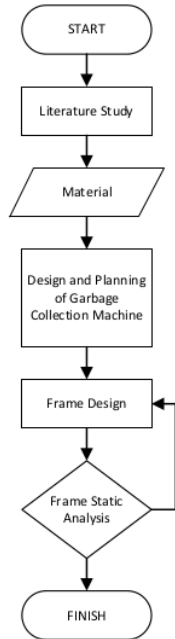

Figure 1. flowchart of Design and Analysis of Garbage Transport Machine Frame

2.2 Design Stages

In the process of designing and planning river flow garbage transporting machines using the rapid prototyping method, this is a technology used to create three-dimensional models from computer-aided design (CAD) using solidworks 2021 software, which is capable of conducting tests and simulations, such as analyzing von misses stress, displacement, and factor of safety. In this plan, a build of material is needed in the manufacture of river flow garbage collection machines, the following are these components.

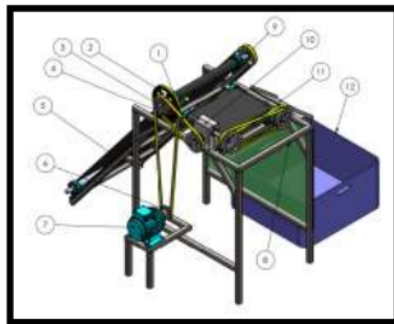

Figure 2. River Flow Garbage Transport Machine

Caption

- | | |
|-------------------|-------------------------------------|
| 1. V-Belts | 7.AC motors |
| 2. Shaft Pulley | 8. Frame |
| 3. Shaft | 9. Pillow Block Bearings / Bearings |
| 4. Shaft Pulley | 10. Speed Reducer (Gearbox) |
| 5. Conveyor Belts | 11. Hoppers |
| 6. Motor Pulleys | 12. Trash Storage Tub |

3.3 Analysis of Static Tests on Frames Using Solidworks 2021

After planning and analyzing the strength of the material, a simulation process is carried out to determine the value of the von misses stress, displacement and safety of factor. By determining the loading simulation and inputting the data used to carry out the running program process, namely:

1. Determine the Type of Simulation

In this problem, the author conducts an analysis using the Solidworks 2021 software and the analytical method used is the Static method. This method is a model to determine the ability of the structure of a part with certain materials.

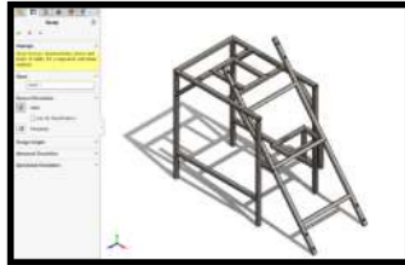

Figure 3. Selection of Static Simulations in Solidworks 2021

2. Material Selection

The material used for the frame is Galvanized Steel. This material has available material properties and standards used in international units.

3. RESULT AND DISCUSSION

3.1 Define Fixed Geometry

Select Fixtures Advisor, then select Fixed Geometry or determine the part of an object that is considered rigid or not moving (fixed). If it is wrong to determine the position of the fixed geometry then the results of the analysis will be fatal and affect the value of the safety factor.

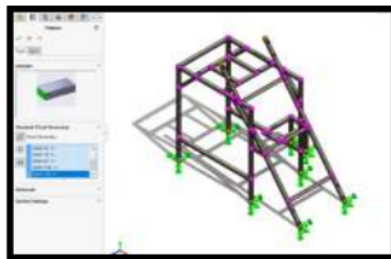

Figure 4. Selection of Fixed Geometry in Frame Testing

After the fixed Geometry process, then enter the next stage, namely giving the load (external load). In this analysis, laying is carried out in three different loading sections of the frame.

a. Top frame loading

In the calculation of the load on the upper frame are the components which include Speed Reducer, Shaft Pulley, Shaft, Bearing Bearing (Pillow Block), conveyor belt, V-belt, Hopper and trash. The weight of the component is assumed to be based on the weight of the components on the market and field conditions.

Table 1. Top Frame Components

No	Component	Total	Mass Component (Kg)	Gravity Force Component (N)
1.	Speed Reducer	1	8	78,453
2.	Shaft	2	2	19,613

No	Component	Total	Mass Component (Kg)	Gravity Force Component (N)
3.	Belt Conveyor	1 m	6	58,84
4.	Pillow Block	4	3,2	31,381
5.	Rubbish		3	29,419
6.	Shaft Pulley	5	1,05	10,297
7.	V-belt	3	1,95	19,123
8.	Hopper	1	0,5	4,903
	Total	17	25,7	252,029

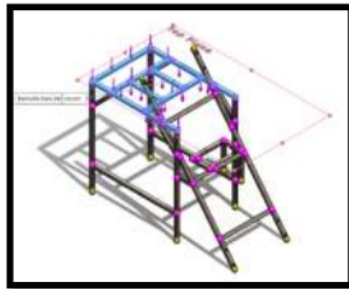

Figure 5. Giving Force Load on the Upper Frame

b. Providing Lean Frame Load

In the calculation of the load on the inclined frame, the components include the shaft pulley, axle, bearing bearing (Pillow Block), conveyor belt, trash. The weight of the component is assumed to be based on the weight of the component on the market.

Table 2. Slanted Frame Components

No	Component	Total	Mass Component (Kg)	Gravity Force Komponen (N)
1.	Shaft	2	2	19,613
2.	Belt Conveyor	3 m	18	176,52
3.	(Pillow Block)	4	3,2	31,381
4.	Rubbish		4	39,226
5.	Shaft Pulley	3	0,63	6,178
6.	Main Shaft Pulley	1	1	9,8
	Total	13	28,83	282,718

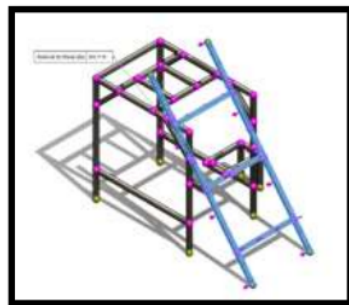

Figure 6. Giving Force Load on the Slanted Frame Section

c. Giving Underframe Load

In the calculation of the underframe load, the components include an AC motor 1 hp 1 phase 1400 rpm and a motor pulley.

Table 3 Underframe Components

No	Component	Total	Mass Component (Kg)	Gravity Force Coponent (N)
1.	AC Motor 1 hp 1 phase 1400 rpm	1	8	78,453
2.	Pulley Motor	1	0,20	1,961
Total		2	8,2	80,414

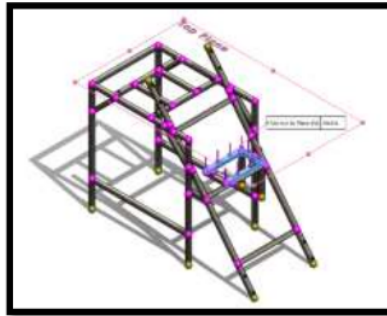

Figure 7. Giving Force Load on the Underframe

3.2 Von Misses Stress Analysis Results

Stress distribution that occurs in all parts of the frame modeling with the selection of Galvanized Steel material. From the simulation results for the maximum stress value for axial and bending stress of 75.38 N/mm² (MPa) and for the minimum axial stress value and bending stress of 0.06 N/mm² (MPa) value the yield strength is 203.94 Mpa, so that the structure does not experience plastic deformation.

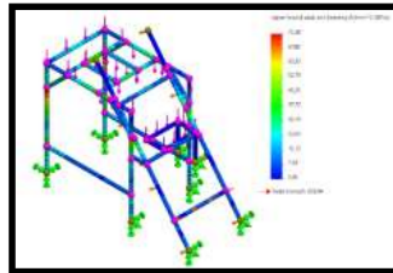

Figure 9. Results of Von Misses Stress Analysis

3.3 Displacement Analysis Results

Displacement is a change in the shape of an object subjected to a force. From the simulation results, it is obtained that the maximum displacement value on the waste transport machine frame is 0.61 mm with the highest displacement point being at the upper end of the inclined frame, and the minimum displacement value obtained is 0.00 mm located on the legs of the machine frame. garbage collector.

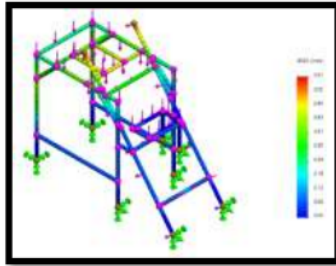

Figure 10. Displacement Analysis Results

3.4 Results of Factor Of Safety Analysis

After knowing the results of the value of the voltage (von misses), then look for the results of the Factor of Safety value. The Factor of Safety value obtained is an automatic calculation value with the help of the Solidworks 2021 software in the test of 3.55 ul.

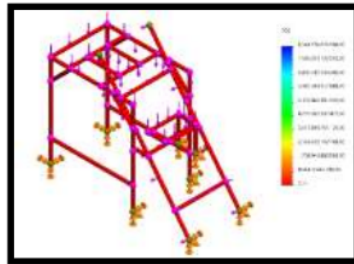

Figure 11. Results of Factor of Safety Analysis

3.5 Von Misses Stress Theoretical

To determine the value of the von misses stress on the frame of the waste transporting machine, it is necessary to have a value of the shear stress (τ) and also the normal stress (σ) from the loading given to the frame of the waste transport machine.

Calculating Loading Force

$$F = m \times g$$

1. Upper Frame loading force
 $F_1 = 25,7kg \times 9,81m/s^2$
 $F_1 = 252,029 N$
2. Tilted Frame loading force
 $F_2 = 28,83kg \times 9,81m/s^2$
 $F_2 = 282,718 N$
3. Lower frame loading force
 $F_3 = 8,2kg \times 9,81m/s^2$
 $F_3 = 80,414 N$

The total results of the calculation of the loading force on each surface are:

$$F_{total} = F_1 + F_2 + F_3$$

$$F_{total} = 252,029 N + 282,718 N + 80,414 N = 615,161 N$$

Maximum Von Misses Stress

$$\sigma_{max} = \frac{\sigma_x + \sigma_y}{2} + \sqrt{\left(\frac{\sigma_x - \sigma_y}{2}\right)^2 + (\tau_{xy})^2}$$

$$\sigma_{max} = \frac{71,99 \text{ N/mm}^2 + 0}{2} + \sqrt{\left(\frac{71,99 \text{ N} + 0}{2}\right)^2 + (0,089 \text{ N/mm}^2)^2}$$

$$= 35,99 + \sqrt{323,96 + 0,0079} = 35,99 + 36$$

$$\sigma_{max} = 71,99 \text{ N/mm}^2$$

From the calculation of the von misses stress of 71.99 N/mm² or 71.99 Mpa.

3.6 Displacement Theoretical

$$\delta = \frac{F \cdot L^3}{48 \cdot E \cdot I}$$

$$\delta = \frac{615,161 \text{ N} \cdot (790 \text{ mm})^3}{48 \cdot 200000 \frac{\text{N}}{\text{mm}^2} \cdot 67500 \text{ mm}^4}$$

$$\delta = \frac{3,03 \times 10^{11}}{6,48 \times 10^{11}}$$

$$\delta = 0,46 \text{ mm}$$

3.7 Factor of Theoretical Safety

In determining the Safety Of Factor can be determined by the theoretical formula:

Yield Streight Material : The yield stress of the Galvanized Steel material is 203.94 Mpa.

Von Misses Max : The maximum stress generated.

$$FOS = \frac{203,94 \text{ Mpa}}{71,99 \text{ Mpa}}$$

$$FOS = 2,83 \text{ ul}$$

4. CONCLUSION

Based on the results of the discussion that has been carried out regarding the Design and Analysis of the Machine Frame for Transporting Garbage in River Flows with a Conveyor System, several conclusions can be drawn which can be written as follows:

1. In designing a garbage collection machine using Solidworks 2021 software, the first thing is to determine the dimensions of the frame, the dimensions used are 1320 mm in length, 790 mm in width and 1133 mm in height. The material used in the frame of the garbage collection machine is Galvanized Steel material with a rod size of 30 x 30 x 2.6 (mm).

2. The simulation results on the frame of the garbage collection machine using solidworks 2021 software, get a von misses stress value with a maximum stress value of 75.38 N/mm² (MPa) and for a minimum stress value obtained of 0.06 N/mm² (MPa), the displacement with the maximum stress value is 0.61 mm and for the minimum stress value is 0.00 mm, the safety factor is 3.55 ul. In the comparison of solidworks and theoretical software values, the value for von misses stress is 0.04%, for displacement is 0.24%, and for safety factor is 0.20%.

REFERENCES

- [1] Abdul Rahman Agung Ramadhan, Eko Aprianto, & Abdul Muchlis. (2021). Static Strength Analysis of Meat Grinder Frame . International Journal of Science, Technology & Management, 2(6), 2179-2186. <https://doi.org/10.46729/ijstm.v2i6.390>

- [2] Wang, X., & Gu, H. (1997). Static analysis of frame structures by the differential quadrature element method. *International Journal for Numerical Methods in Engineering*, 40(4), 759-772.
- [3] Maciel, D. N., & Coda, H. B. (2005). Positional description for non-linear 2d static and dynamic frame analysis by fem with reissner kinematics. *Computational fluid and Solid Mechanics*. MIT, MIT, Boston.
- [4] Patil, N. R., Kulkarni, R. R., Mane, B. R., & Malve, S. H. (2014). Static analysis of go-kart chassis frame by analytical and SolidWorks simulation. *International Journal of Scientific Engineering and Technology*, 3(5), 661-663.
- [5] Steffen, J. (2013). *Analysis of Machine Elements Using Solidworks Simulation 2013*. SDC publications.
- [6] Nasution, A. R., & Widodo, E. (2022). Numerical Analysis of Low Carbon Steel Tensile Strength Using Software (SolidWorks). *REM (Rekayasa Energi Manufaktur) Jurnal*, 7(1), 1-6.

DESIGN AND ANALYSIS OF THE FRAME STRENGTH OF WASTE TRANSPORTING MACHINE USING SOLIDWORKS

ORIGINALITY REPORT

8%

SIMILARITY INDEX

7%

INTERNET SOURCES

7%

PUBLICATIONS

0%

STUDENT PAPERS

PRIMARY SOURCES

1

journal.admi.or.id

Internet Source

6%

2

core.ac.uk

Internet Source

<1%

3

Arya Rudi Nasution, Edi Widodo. "Numerical Analysis of Low Carbon Steel Tensile Strength Using Software (SolidWorks)", R.E.M. (Rekayasa Energi Manufaktur) Jurnal, 2022

Publication

<1%

4

Sathishkumar Aruchamy, Soundararajan Ranganathan, Dharini Arumugam Chithrambikai, SANTHOSH BABU. "Design and Analysis of Mini - Tractor Chassis", SAE International, 2022

Publication

<1%

5

ijstm.inarah.co.id

Internet Source

<1%

Exclude quotes On

Exclude matches Off

Exclude bibliography On